

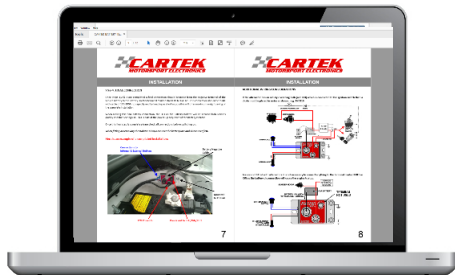

## ***GEAR INDICATOR (Club)***



## ***INSTALLATION GUIDE***



For the very latest information and extra  
installation advice go to:  
[www.cartekmotorsport.com/downloads](http://www.cartekmotorsport.com/downloads)

## GEAR INDICATOR INTRODUCTION (Club)

The **GEAR INDICATOR** from **CARTEK** is a dashboard mounted device that is designed to indicate to a driver the current selected transmission gear and also incorporates a gear shift-light display which can indicate to a driver the optimum time to shift up a gear. The selected gear is indicated by a large, multi-coloured, 7 segment numerical display while the shift-light function is displayed at the upper part of the unit by 8 multi-coloured LEDs. These 8 LEDs form a display sequence that will commence at an engine speed prior to optimum and complete at precisely the optimum speed thereby giving the driver early indication to shift up before the rev limiter is reached or engine damage occurs.

### Gear Indicator (Club)

The Gear Indicator (Club) can be used on most transmission types including manual 'H' pattern, sequential, DSG and automatic. The Gear Indicator can be connected directly to sequential gearboxes that are equipped with an analogue voltage gear position sensor (Sensor Voltage method) or it can determine the selected gear by calculating the ratio between Engine Speed and Road Speed (Ratiometric method).

#### CONNECTION DIAGRAM

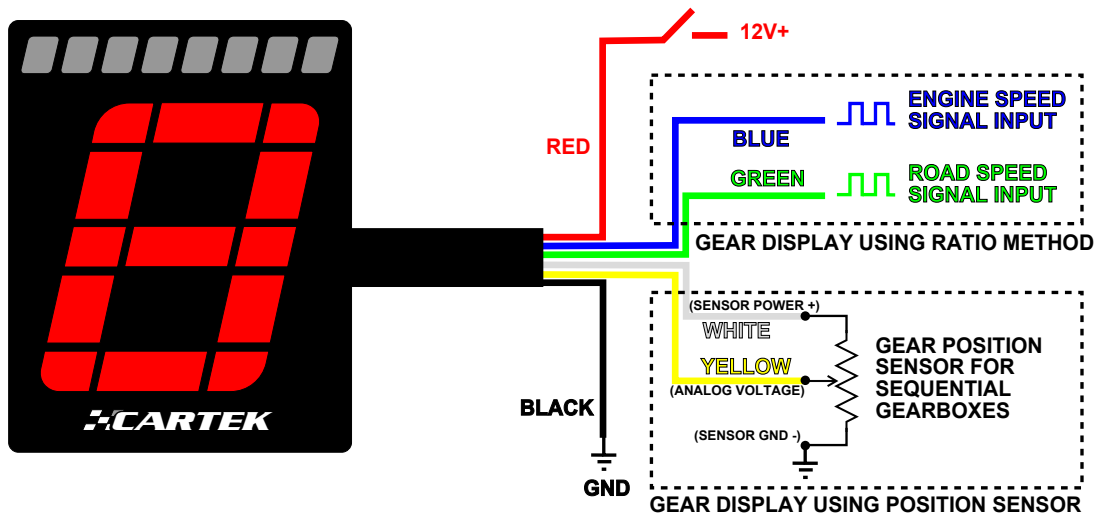

**NOTE: If Sensor Power is not required then it must be insulated**

#### MOTORSPORT IS DANGEROUS.

**THIS PRODUCT IS DESIGNED FOR MOTORSPORT USE ONLY AND SHOULD NOT BE USED ON ROAD/STREET VEHICLES OR ON PUBLIC HIGHWAYS.**

**NO WARRANTY IS MADE OR IMPLIED REGARDING ANY CARTEK PRODUCTS TO PROTECT USERS FROM INJURY OR DEATH.**

**USER ASSUMES ALL RISKS.**



## **CONFIGURATION** GEAR INDICATOR *Club*

After installing the Gear Indicator, and with the ignition switched ON, Configuration Mode can then be entered where various settings can be checked or adjusted.

**Configuration Mode** is entered by pressing and holding the pushbutton on the rear of the unit. After 2 seconds the gear display will begin flashing 'G'. Releasing the pushbutton at this point will select the **Gear-Indicator** configuration menus. However, if you wish to enter the **Shift-Light** configuration menus then continue to hold the pushbutton until the upper Shift-Light LEDs begin to flash and then release it.

### **GEAR-INDICATOR CONFIGURATION MENUS**

The Gear-Indicator Configuration Menus are entered when the pushbutton is released while 'G' is flashing on the gear display. There are **5** Gear-Indicator settings that can be adjusted. To select the required Gear-Indicator Configuration Menu press and hold the pushbutton again. The display will now cycle through the digits 1-5 indicating menus 1-5. When the required menu is displayed then release the pushbutton.

Here are the 5 Gear-Indicator configurations that can be adjusted:

<b>Configuration Menu</b>	<b>Digit Displayed</b>	<b>Description</b>
1	1	<b>Gear Indicator Brightness Level</b>
2	2	<b>Gear Indicator Display Colour</b>
3	3	<b>Number of Forward Gears</b>
4	4	<b>Gear Ratio Learning mode</b>
5	5	<b>Gear Calculation method</b>

Each Configuration is described in more detail later. Any changes to a configuration are saved immediately.

#### **Configuration Menu Exit:**

There are 3 ways to exit any Configuration Menu:

1. Remove power from the Gear-Indicator (switch the ignition OFF). Any adjustments made will be saved for use next time it is powered up.
2. Whilst in a configuration menu, press and hold the pushbutton for **2** seconds. Doing this will result in any new setting being saved and the Gear Indicator exiting Configuration Mode and ready for normal use.
3. Whilst in a configuration menu, press and hold the pushbutton for **4** seconds. Doing this will result in any new setting being saved and Configuration Mode moving onto the next available Configuration Menu.

#### **Factory Reset**

If you wish to return to the factory/default settings then a 'Factory Reset' can be performed. To do this, switch the ignition OFF then, while pressing and holding the pushbutton, switch the ignition back ON. The outer LEDs will display Blue. Continue to hold the pushbutton until the outer LEDs begin flashing, which will indicate that the default settings have been restored. The pushbutton can now be released.

LED Brightness Levels:	<b>Day Brightness = Maximum, Night Brightness = Minimum</b>
Gear Display Colour:	<b>Red</b>
Number of Forward Gears:	<b>6</b>
LED Shift Light Pattern:	<b>Blue / Red Linear display (Pattern 1)</b>
Shift Light engine speed:	<b>2,200 RPM - 8,200 RPM</b>
Default gear Calculation method:	<b>Ratiometric</b>



## CONFIGURATION GEAR INDICATOR *Club*

### Configuration Menu 1 - Gear-Indicator Digit Brightness:

Note: This configuration is for the Gear-Indicator digit only. Shift-Light display brightness is separate and described later.

There are two adjustable brightness levels, **Day** brightness level or **Night** brightness level. During normal operation (not in configuration mode) a simple press of the rear button will switch between the two brightness levels. To adjust the Gear-Indicator Day or Night brightness levels, select Gear-Indicator Configuration menu 1, as described previously.

On selecting Configuration Menu 1 the left column of LEDs will illuminate at the current brightness for **Day** use. Quick presses of the pushbutton will then display each of the 10 brightness levels available. When the preferred brightness level is displayed then press and hold the pushbutton for 2 seconds to save the setting and exit Configuration Mode. Or, press and hold the pushbutton for 4 seconds to save the setting and move on to adjusting **Night** brightness. Night brightness level will be indicated by the right column of LEDs and is adjusted in the same way as Day brightness level. When the preferred brightness level is displayed then press and hold the pushbutton for 2 seconds to save the setting and exit Configuration Mode. Or, press and hold the pushbutton for 4 seconds to save the setting and move on to the next menu.

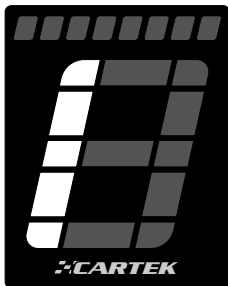

Day brightness

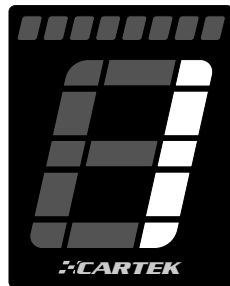

Night brightness

### Configuration Menu 2 - Gear-Indicator Digit Colour:

To adjust the colour of the Gear-Indicator Digit, select Configuration Menu 2 as described previously.

On selecting Menu 2 the digit '8' will be displayed in the current selected colour. Quick presses of the pushbutton will then display each of the 7 colours available. When the preferred colour is displayed then press and hold the pushbutton for 2 seconds to save the setting and exit Configuration Mode. Or, press and hold the pushbutton for 4 seconds to save the setting and move on to the next menu.

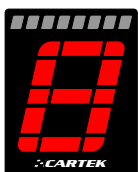

Red



Blue

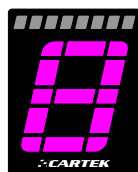

Purple

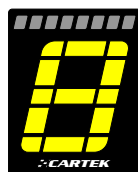

Yellow

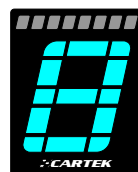

Cyan



White

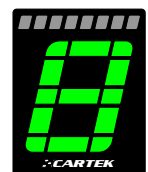

Green



## **CONFIGURATION** GEAR INDICATOR *Club*

### **Configuration Menu 3 - Gear-Indicator Number of Forward Gears:**

Before the Gear Indicator can learn the gear ratios from the car's transmission, or voltage values from a sequential gearbox gear position sensor, it needs to know how many forward gears the transmission has. To adjust the Number of Forward Gears, select Configuration Menu 3 as described previously.

On selecting Configuration Menu 3 the current Number of Forward Gears will be displayed. Quick presses of the pushbutton will then increment the Number of Forward Gears between 2-8. When the correct Number of Forward Gears is displayed then press and hold the pushbutton for 2 seconds to save the setting and exit Configuration Mode. Or, press and hold the pushbutton for 4 seconds to save the setting and move on to the next menu.

### **Configuration Menu 4 - Gear-Indicator Learning Mode:**

There are two methods for learning gears, Ratiometric or Sensor Voltage (See Configuration 5).

#### **4.1) Gear-Indicator Learning Mode (Ratiometric method):**

When using the Ratiometric method, the Gear-Indicator needs to learn the ratio between engine speed and road speed for each of the transmission's gear ratios. Therefore, the Engine Speed and Road Speed signal wires must both be connected and receiving compatible speed signals and Ratiometric method must be selected in Configuration Menu 5.

For the Gear-Indicator to learn these ratios it is necessary to drive the car steadily in each gear therefore consideration should be given to where the car can be driven safely in all gears.

On selecting Configuration Menu 4 'L' will be displayed to indicate that you are about to enter Learning Mode. If you do not wish to perform the Learning Mode then press and hold the pushbutton for 2 seconds to exit. When you are ready to begin driving, press the pushbutton again whereupon '0' will begin flashing to indicate it is waiting for the car to begin moving. Note: If '0' does not appear then this indicates the engine is not running or engine RPM signal is not connected to the Blue wire.

Once the Gear-Indicator detects the car is moving then the display will begin flashing '1' in red. At this point the driver should drive at a steady speed in Gear 1 until the '1' goes green. After briefly displaying green the Gear Indicator will save the gear ratio before then incrementing to the next gear, Gear 2. At this point the driver should shift up to the next gear and again drive at a steady speed until the digit turns green again. When the final gear ratio is learnt then the Gear-Indicator will automatically exit Configuration Mode and will now display each gear every time a gear shift occurs. Note: If the display shows only '0' when the car is moving then this indicates that the Road Speed is not connected to the Green wire.

#### **Note:**

When in Learning Mode and driving the car in each requested gear, it does not matter if you need to shift back down a gear, or even stop. Learning Mode will continue to wait for the next higher gear and will not over-write lower gears once they have been learnt and saved.

If installed on a car with automatic transmission then set the the transmission to manual mode so that you have full control over the gear selection and only shift up when the Gear Indicator requests it.



## **CONFIGURATION** GEAR INDICATOR *Club*

### **4.2) Gear-Indicator Learning Mode (Sensor Voltage Method):**

When using the Sensor Voltage method, the Gear-Indicator needs to measure and learn the gear position sensor output voltage for each gear including Neutral and Reverse if available. Therefore, the Gear-Indicator must be connected to a suitable gear position sensor, as shown in the Connection Diagram on page 1. Also, the **Number of Forward Gears** should be set using **Configuration Menu 3**, described earlier, and **Sensor Voltage method** must be selected in **Configuration Menu 5**, described later.

On selecting Configuration Menu 4 'L' will be displayed to indicate that you are about to enter Learning Mode. If you do not wish to perform the Learning Mode then press and hold the pushbutton for 2 seconds to exit. Entry into Learning Mode is confirmed with another quick press of the pushbutton whereupon the display will begin flashing 'n' in red. At this point the driver should put the transmission into Neutral. Once in Neutral, press the pushbutton to confirm this whereupon the Gear-Indicator will then measure the output voltage of the Gear Position Sensor and store it as the Neutral voltage value. The Gear-Indicator will then move on to Gear 1 gear as indicated by displaying '1'. At this point the driver should set the transmission to Gear 1 and again press the pushbutton. This shall be repeated until all forward gear voltage values have been measured and stored.

After the highest forward gear has been learnt, the display will flash 'r'. If the transmission is equipped with a Reverse gear then the transmission should put into Reverse gear and the pushbutton pressed for the final time. If the transmission does not have a Reverse Gear then press and hold the pushbutton until the display goes blank to exit Learning Mode.

### **Configuration Menu 5 - Gear Calculation method:**

As mentioned earlier, there are two methods for calculating and displaying the current gear, Ratiometric or Analogue Voltage. The correct method needs to be checked, and adjusted if necessary, before performing Learning Mode (Configuration Menu 4).

On selecting Configuration Menu 5 either 'r' or 'A' will be displayed to indicate either Ratiometric method or Analogue Voltage method has been selected. If the method needs to be changed then a quick press of the pushbutton will allow selection of either method, 'r' Ratiometric or 'A' Analogue Voltage. When the correct method is displayed then press and hold the pushbutton for 2 seconds to save the setting and exit Configuration Mode. Or, press and hold the pushbutton for 4 seconds to save the setting and move on to the next menu.



## CONFIGURATION GEAR INDICATOR *Club*

### SHIFT-LIGHT CONFIGURATION MENUS

**Configuration Mode** is entered by pressing and holding the pushbutton on the rear of the unit. After 2 seconds the gear display will begin flashing 'G'. To enter the **Shift-Light** configuration menus, continue to hold the pushbutton until the upper Shift-Light LEDs begin to flash and then release it.

To select the required Shift-Light Configuration Menu press and hold the pushbutton again. The display will now cycle through the upper LEDs 1-6 indicating Configuration Menus 1-6. When the required menu is displayed then release the pushbutton.

Here are the 4 Shift-Light configurations that can be adjusted:

Configuration Menu	LEDs Displayed	Description
1	1	LED Brightness Level
2	2	LED Shift Light Pattern
3	3	Shift Light Pattern Start RPM
4	4	Shift Light Pattern End RPM
5	5	RPM Signal Input Filtering
6	6	Pulses per Crank Shaft Revolution

#### Configuration 1 - Shift-Light Brightness:

Note: This configuration is for the Shift-Light display only. Gear-Indicator digit brightness is described earlier.

There are two adjustable brightness levels, **Day** brightness or **Night** brightness. During normal operation (not in Configuration mode) a simple press of the rear button will switch between Day and Night brightness levels. To adjust the Shift-Light, Day or Night, brightness levels select Shift-Light Configuration Menu 1.

On selecting Menu 1, the four leftmost Shift-Light LEDs will illuminate at the current brightness for Day use. Quick presses of the pushbutton will then display each of the 10 brightness levels available. When the preferred brightness level is displayed then press and hold the pushbutton for 2 seconds to save the setting and exit Configuration Mode. Or, press and hold the pushbutton for 4 seconds to save the setting and move on to adjusting **Night** brightness. Night brightness level will be indicated by the four rightmost Shift-Light LEDs and is adjusted in the same way as Day brightness level. When the preferred brightness level is displayed then press and hold the pushbutton for 2 seconds to save the setting and exit Configuration Mode. Or, press and hold the pushbutton for 4 seconds to save the setting and move on to the next menu.

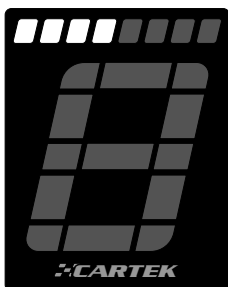

Day brightness

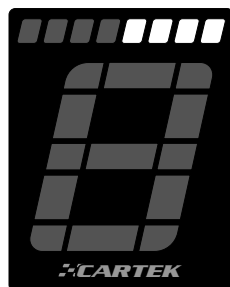

Night brightness

## CONFIGURATION GEAR INDICATOR *Club*

### Configuration 2 - Shift-Light Pattern:

On entering Configuration Menu 2, the upper LEDs will demonstrate the current selected Shift-Light pattern. Subsequent quick presses of the pushbutton will cycle through each of the 6 available Shift-Light patterns shown below:

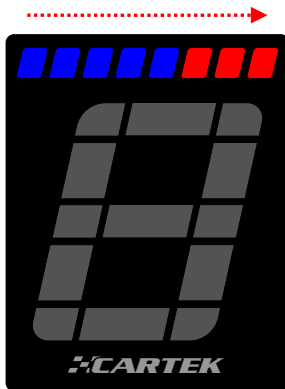

Pattern 1 - Linear

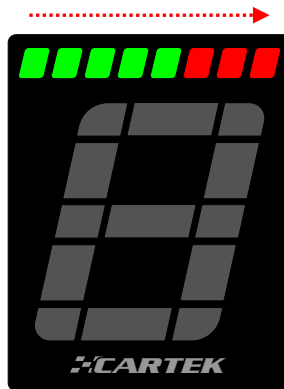

Pattern 2 - Linear

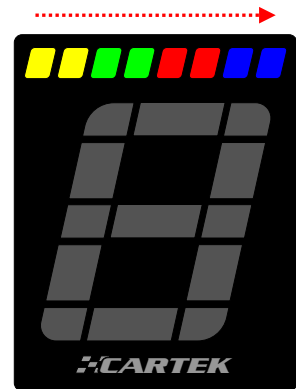

Pattern 3 - Linear

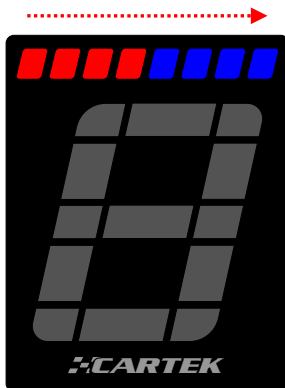

Pattern 4 - Linear

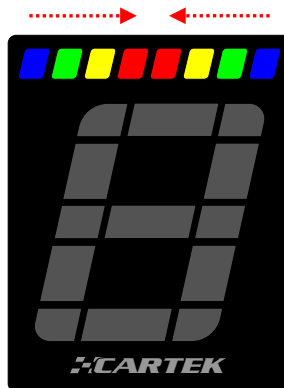

Pattern 5 - Converging

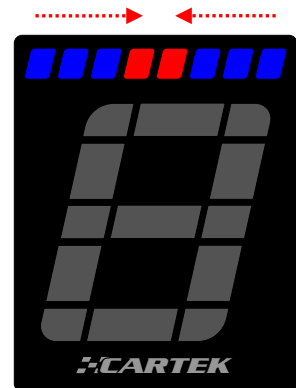

Pattern 6 - Converging

When the preferred pattern is displayed then press and hold the pushbutton for 2 seconds to save the setting and exit Configuration Mode. Or, press and hold the pushbutton for 4 seconds to save the setting and move on to the next menu.



## CONFIGURATION GEAR INDICATOR Club

### Configuration 3 - Shift Light Pattern START RPM:

There are two methods available for setting the Shift-Light Pattern START RPM. This can be done by using the pushbutton to enter an exact required RPM value, or running the engine at half the required engine speed.

#### 3.1) Shift Light Pattern START RPM using the pushbutton (Engine must be stationary)

Firstly, consider the actual engine speed (RPM) that you wish the display to start. This RPM value will be entered as separate numbers, i.e. 10,000, 1,000, 100 and 10. Any RPM value can be entered up to 19,990 RPM in steps of 10 RPM. Perhaps write the required speed onto a piece of paper, e.g. 5,500 RPM = 0 5 5 0.

On entering Configuration Menu 3 when the engine is stationary, the display will show one Red LED followed by 3 Green LEDs on the **left** side of the display. This will be displaying the current 10,000RPM setting. Static, (no flashing) will represent 0x 10,000, 1 flash will represent 1x 10,000, etc. Quick presses of the pushbutton will allow the value to be adjusted, however, only two values are available, 0x 10,000 and 1x 10,000.

Pressing and holding the pushbutton for a minimum of 4 seconds will cause the configuration to move onto the next RPM factor, **1,000RPM**. This value can be adjusted with quick presses of the pushbutton which will result in the value incrementing, e.g. static, (no flashing) will represent 0x 1,000, 9 flashes will represent 9x 1,000 (9,000).

Pressing and holding the pushbutton again for a minimum of 4 seconds will cause the configuration to move onto the next RPM factor, **100RPM**. This value can also be adjusted with quick presses of the pushbutton which will result in the value incrementing.

Pressing and holding the pushbutton again for a minimum of 4 seconds will cause the configuration to move onto the last RPM factor, **10RPM**. This value can also be adjusted with quick presses of the pushbutton which will result in the value incrementing.

If only the Start RPM value is to be adjusted then press and hold the pushbutton for 2 seconds to save the Start RPM value and exit Configuration Mode. Or, press and hold the pushbutton for 4 seconds to save the Start RPM value and move on to Configuration Menu 4 to set the End RPM value.

Configuration:  
Start of sequence RPM

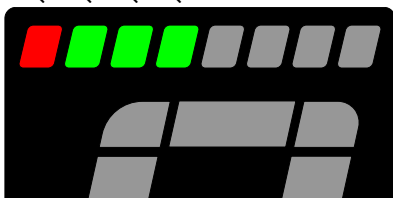

Example:  
Start of sequence = 06450 RPM





## CONFIGURATION GEAR INDICATOR Club

### 3.2) Shift-Light Pattern START RPM using tachometer (Engine must be running)

This method of setting the display sequence START RPM will require the engine to be run at half the preferred speed. This means the engine does not need to be driven at high RPM but make sure the engine is up to normal running temperature before commencing this procedure.

To indicate that the Shift-Light is waiting to measure the engine speed for the pattern START RPM, the four LEDs on the **left** side will flash Green. At this point the driver needs to hold the engine speed at **half** the required RPM. When the driver is satisfied that the engine is running at half of the required speed, the pushbutton should then be pressed. The Shift Light will then measure the engine speed, double it, and store it in memory as the Shift-Light Pattern START RPM value. This will be acknowledged by the four LEDs changing to Red.

If only the START RPM value is to be adjusted then press and hold the pushbutton for 2 seconds to save the START RPM value and exit Configuration Mode. Or, press and hold the pushbutton for 4 seconds to save the START RPM value and move on to Configuration Menu (4) to set the Upper RPM value.

Note: If the Shift Light fails to enter **Shift-Light Pattern START RPM using tachometer** menu but enters **Shift Light Pattern START RPM using the pushbutton** instead, then this would indicate that it is not receiving a suitable RPM signal on the Blue wire.

### Configuration 4 - Shift Light Pattern END RPM:

As with Configuration Menu 3, the same two methods are available for setting the Shift Light Pattern END RPM: Entering the specific engine speed value using the rear pushbutton, or running the engine at half the required engine speed.

### 4.1) Shift Light Pattern END RPM using the pushbutton (Engine must be stationary)

This procedure is identical to Configuration Menu 3.1 but the LEDs are now displayed on the **right** side of the Shift Light. Follow the same instructions as Configuration Menu 3.1 to check or adjust the END RPM value.

Configuration:  
End of sequence RPM

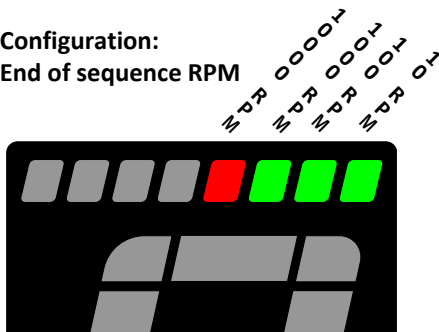

Example:  
End of sequence = 10,500 RPM

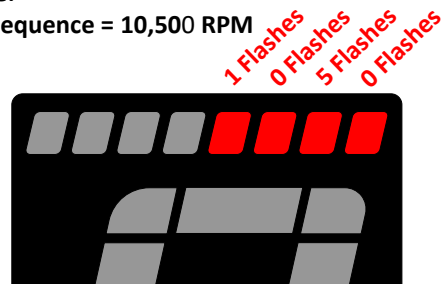

### 4.2) Shift Light Pattern END RPM using tachometer (Engine must be running)

This procedure is identical to Configuration Menu 3.2 but the LEDs are now displayed on the **right** side of the Shift Light. Follow the same instructions as Configuration Menu 3.2 to set the END RPM value by running the engine at half the preferred speed.



## **CONFIGURATION** GEAR INDICATOR *Club*

### **Configuration Menu 5 - RPM Signal Input Filtering :**

There is a choice of two filters for the input RPM signal:

**Filter 1** is suited to clean, electronic / ECU RPM signals and suits modern, high revving engines.

**Filter 2** is suited to RPM signals taken from the negative side of the ignition coil which can be electrically noisy and is especially suited to older, lower revving engines and historic cars with contact breaker style ignition systems.

On entering Configuration Menu 5, the LEDs will display the current selected filter by illuminating Blue LEDs, i.e. 1 Blue LED = Filter 1, 2 Blue LEDs = Filter 2.

Subsequent quick presses of the pushbutton will switch between the two filter choices.

Once the filter has been chosen then press and hold the pushbutton for 2 seconds to save the setting and exit Configuration Mode. Or, press and hold the pushbutton for 4 seconds to save the setting and move on to the next menu.

### **Configuration Menu 6 - Pulses per Rev :**

On entering Configuration Menu 6, the LEDs will display the current number of Pulses per Rev (sparks per crankshaft revolution) by illuminating Yellow LEDs, e.g. 2 (non-flashing) Yellow LEDs = 2 Pulses per Rev. Half a pulse is shown by a flashing yellow LED, e.g. 1 (flashing) Yellow LED = 1/2 Pulse per Rev (2 Revs per Pulse). This value can be set from 0.5 to 8, so most engine configurations are catered for, e.g. a typical 4 cylinder, 4-stroke engine creates 2 pulses per crankshaft revolution. 2 Pulses per Rev is the default value, and many ECUs also use this ratio irrespective of the number of cylinders.

Subsequent quick presses of the pushbutton will increment the Pulses per Rev value.

Once the Pulses per Rev value has been set then press and hold the pushbutton for 2 seconds to save the setting and exit Configuration Mode. Or, press and hold the pushbutton for 4 seconds to save the setting and move on to the next menu.

### **MOUNTING**

The Gear Indicator unit should be mounted securely on the dashboard where the display can be clearly seen by the driver. Mounting can be by two M3 screws from the underside or two M3 screws from the rear of the unit.

Note: If mounting using screws from the underside then the maximum thread depth is just 8mm.

See drawing on next page.

